

DIMENSIONS

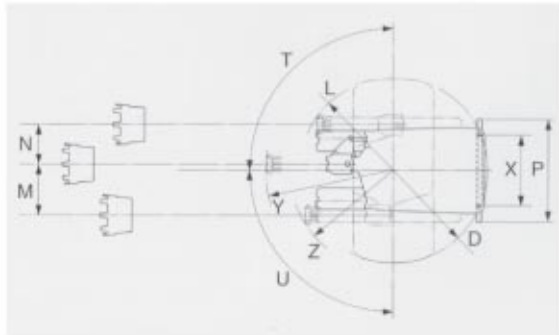
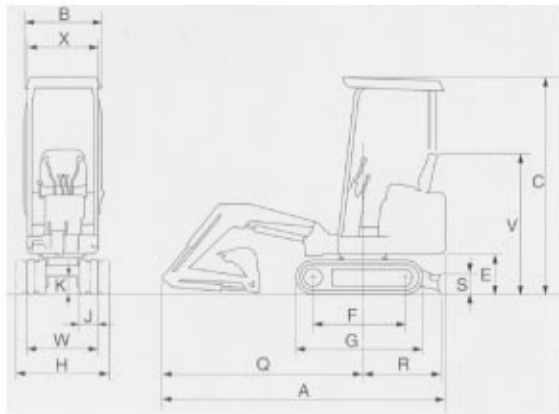

	mm
A	2710
B	740
C	2110/2195
D	800
E	385
F	900
G	1220
H	900
J	180
K	160
L	790
M	440
N	340
P	900
Q	1920
R	740
S	200
T	90°
U	90°
V	1375
W	680
X	680
Y	1080
Z	880

SPECIFICATIONS (Canopy, Rubber Tracked, Breaker Piping Standard Fops/Tops Canopy, Standard Arm)

Machine weight	835kg
Diesel engine	Water-cooled
Model	TB108
Fuel tank capacity	9.4 litres
Hydraulic tank	7.6 litres

OVERALL DIMENSIONS (mm)

Length (in transport)	2710 mm
Width	740 mm
Height	2110 mm
Rear slew radius	800 mm
Min. ground clearance	160 mm

BUCKET ATTACHMENTS

Hitch pick up	90 mm
Mud	680 mm
Trench	200 mm
General purpose	675 mm

WORKING RANGES

	mm
A Max. digging radius	2825
B Max. floor digging radius	2730
C Max. digging depth	1530
D Max. vertical digging depth	1220
E Max. digging height	2860

PERFORMANCE

Traction speed	2.0 / 3.9 km/h
Gradeability	30° (58%)
Max. dig power bucket	1040 Kgf
Max. dig power arm	675 Kgf

DOZER BLADE (mm)

Width x Height	680 x 200 mm
Operating range up/down	155 x 120 mm

OFF-SET DIG FUNCTION

Type	Boom Swing
Swing angle RH / LH	90° / 90°

TRACTION SYSTEM (mm)

Crawler type	Rubber Track
Crawler shoe width	180 mm

	mm
F Max. dumping height	2030
G Min. dumping height	900
H Max. vertical digging radius	1890
J Max. raising height	155
K Max. lowering depth	120

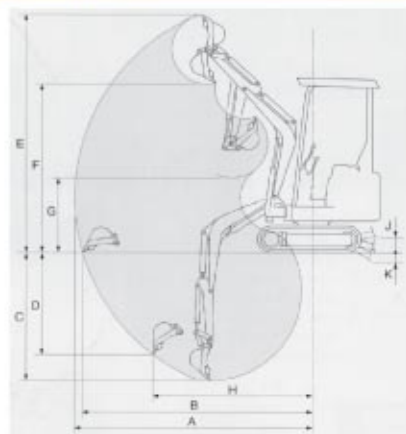

SHERRIN Rentals

BRISBANE • DARWIN • TOOWOOMBA • SUNSHINE COAST

132 138

Email - info@sherrinrentals.com.au Web - www.sherrinrentals.com.au

1 Tonne Excavator